

Needle Bearing U-Joints

Since 1989, Woodward steering universal joints have been the preferred choice of race car builders everywhere, and have won every major race and series championship in North America many times over, including the NASCAR championship. Woodward pioneered the use of caged needle rollers with a slight preload to create a joint without backlash and with noticeably lower reversing inertia than conventional automotive designs. That means enhanced sensitivity at the steering wheel, and makes even the smallest steering input more effective—whether on a superspeedway at 200MPH or sideways on a dirt bull ring.

The bearing trunnion used in these u-joints is a one-piece design of hardened chrome-vanadium tool steel. The grease seals are high-durometer fluorocarbon o-rings in compression against the end surfaces of the needle bearing cups. These seals will resist sustained oven-level heat and will retain the bearing grease under severe conditions, including welding. Other design details include stainless steel truss-head screws overlapping the bearing cups, and a pair of fine-thread knurled set screws located at 90°, for highly positive and reliable retention on a splined shaft or steering gear.

We make a variety of fractional and metric splines to fit automotive and aftermarket steering, in addition to the race-car-only "201" spline used on all Woodward products. Some automotive splines can be difficult to identify, so on the following pages we have provided actual-size silhouettes to help select the correct u-joint.



PLATING: Splined Woodward U-joints are now available gold zinc plated in several of the most popular sizes. Plated joints are baked immediately after plating to prevent hydrogen embrittlement, and all dimensionally critical surfaces are corrected prior to final assembly. For gold zinc where available, add G to the part number. To avoid possible contamination of the weld zone, plain-bore joints intended for welding are not plated.



shown:
UAD1-20201

DOUBLE UNIVERSAL JOINTS: Double U-joints neatly solve problems of angular misalignment by providing a more constant rotational velocity than a single joint used at the same operating angle. These joints are available as short permanent-center units as shown, or assembled onto splined shafts at various center distances. On assembled units the Woodward "201" spline is timed with respect to the bearing axis to provide correct phasing and smooth and reliable operation.

INDUSTRIAL APPLICATIONS: Woodward can manufacture long or short runs of special universal joints for industrial uses such as machine tools, printing presses and assembly and packaging equipment.

MILITARY APPLICATIONS: As part of the defense procurement chain, Woodward supplies steering u-joints for combat vehicles in current production, as well as prototypes.

CUSTOM U-JOINTS: We can produce one-off joints for rare auto restorations, vintage race cars and retrofits. Drawings should be emailed to tech@woodwardsteering.com.



Spline Identification

The diameter shown in parentheses after the part number is the **nominal outside diameter of the shaft the u-joint is intended to fit**, in decimal inches. In production, a spline is measured over wires of specified diameter which fit into the vees. Since it's seldom practical to do this in the field, we suggest you measure the outer diameter. Usually it will correspond closely enough to one of these diameters to identify it. The figure after the dash is the basic number of spline teeth around the circle, not counting flats or interruptions (e.g., a shaft with 36 teeth, 6 of which are missing, is NOT a 30-spline shaft). If interruptions make it impossible to get a reliable count all the way around the shaft, count halfway around and double it.

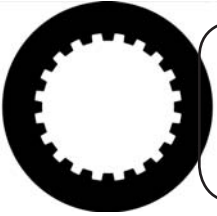

201 (.750-20 spline)

Used on all Woodward products since 1992; fits Woodward integral power racks, Woodward remote power racks, Woodward servos, and Woodward safety steering columns, weld-in stubs, and double u-joints. Also used on copies of Woodward columns. Not an automotive industry profile. The shaft spline OD is cylindrical and can run in a bearing.

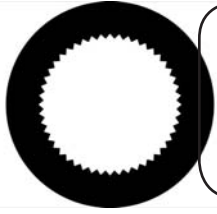

101 (.750-48 spline)

Fits most US stock-car racks past and present (Sweet, Appleton, Speedway, SWS, Quick-trac, Wilwood, Coleman, BRT, RCP, and pre-1992 Woodward) and the output end of large style Sweet servos. Note: Over the years this profile has been used by many aftermarket manufacturers without reference to the original dimensional standard; a proper fit cannot be guaranteed on parts made by companies no longer in business.

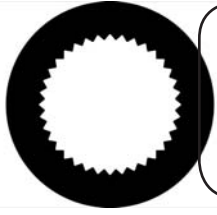

102 (.735-36 spline)

Fits Mustang power rack, Chrysler power steering box, old Chevy and Ford manual boxes and most steering quickeners. Note: This is an automotive industry profile whose production tolerances varied during the half century it was in use. Aftermarket versions vary even more. Some aftermarket shafts and steering quickeners with a "3/4-36 spline" do not conform to this profile and may not work with this joint.

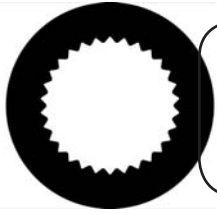

103 (.720-30 spline)

Metric profile introduced on 1980s GM power steering boxes and racks. Used on current Delphi 600 series boxes and on aftermarket servos using the Delphi 600 input shaft (Appleton, small style Sweet, etc.). Interchangeability of this profile is fairly reliable. Usually has a large flat on one side.

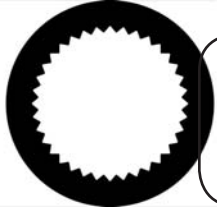

104 (.820-36 spline)

Used on older GM power steering (700 series boxes) and on aftermarket servos using the Delphi 700 input shaft (large style Sweet). The measured diameter varied considerably during the years of production of the steering box, from .812 as originally produced, to .820 on later units. Usually has a large flat on one side.

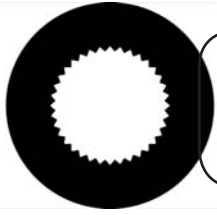

105 (.620-36 spline)

Metric profile, made for OEM Chevrolet Vega steering box (NOTE: may not fit "5/8-36" aftermarket copies of the Vega box).

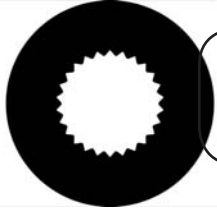

106 (.565-26 spline)

Fits Ford Pinto manual rack and pinion and most aftermarket copies.

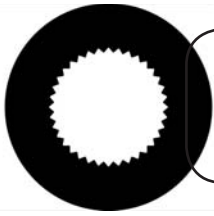

107 (.625-36 spline)

Made specifically for the Stiletto manual rack. A special profile; not an automotive standard, and NOT for Vega steering boxes.

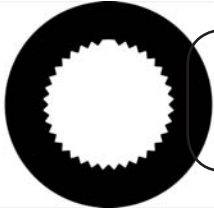

108 (.688-34/36 spline)

Metric-dimensioned, has one filled spline for orientation; fits Toyota truck power steering.

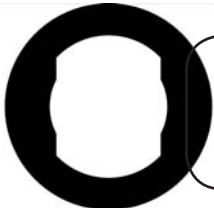

109 (3/4-DD spline)

Fits Ford style DD shaft and aftermarket DD shafting measuring .550 across the flats. Does NOT fit GM DD shaft which is smaller diameter with narrow flats

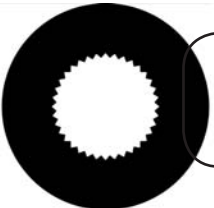

110 (.563-36 spline)

Fits Jack Knight and Titan racks, also some dragster steering.

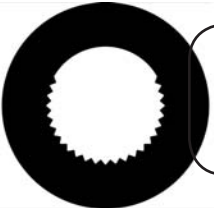

111 (.625-23/36 spline)

Originally made to fit the Australian TRW power rack with 13 blocked or filled splines, this also fits the 16 mm x 36 spline shaft used on various Japanese cars.

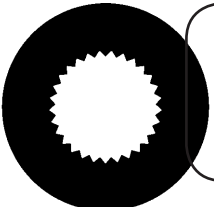

112 (.585-29 spline)

Metric profile; fits Honda rack and pinion and steering column and some aftermarket midget racks.

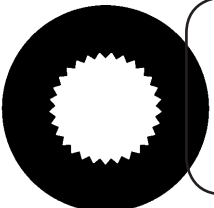

113 (.570-28 spline)

Metric profile; fits Datsun 240/260/280Z. The other end of this u-joint can be sized for welding onto the original steering shaft.

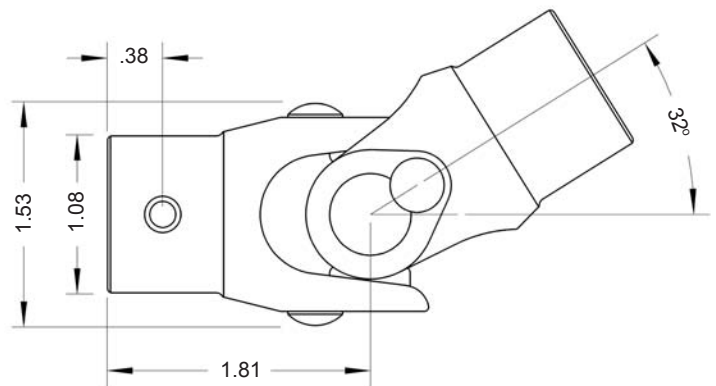

Operating Angle

Although the ears of the joint are contoured to prevent it from jamming,

it will not operate beyond a 32 degree angle. **Any universal joint will transmit rotary motion at constant velocity when straight, but when rotating through an angle it will develop a twice-per-revolution acceleration/deceleration cycle which increases with the angle.** To avoid variable velocity effects in the steering we strongly recommend that the total angular misalignment between steering column and pinion not exceed 20 degrees. Smoothness of operation can be further improved by subdividing the angle between two joints.

Double-splined U-joints:

In all but entry-level classes, the time-honored practice of welding universal joints directly to the steering tubing is gradually being phased out. ST201 weld-in splined stubs allow the use of double-splined, completely removable u-joints. **The stubs are solid, and unlike a splined piece of tubing they cannot be crushed by the set screws.** The slight extra cost of stubs and double-splined joints is almost insignificant compared with the time and effort which must otherwise be invested in welding u-joints, removing welded u-joints with a torch or hand grinder, or trying to modify a steering shaft whose joints have been welded.

U-joints can undergo distortion if they are heat-soaked during a time-consuming welding process, and excessive heat will draw the temper of the needle bearings. Weld-in stubs contain no moving parts and are virtually immune to damage other than spatter. **A guide to welding these parts appears on page 8.**



**.750-20 SPLINE
WELD-IN STUB**

For 3/4 OD x .120 wall	
ST201A	5.30
For 3/4 OD x .065 wall	
ST201B	5.30
Custom (up to .660 pilot)	
ST201X	6.96
Custom (up to .875 pilot)	
ST201GM	16.95



**.750-20 SPLINE x
3/4 WELD-ON**

Woodward spline one end; other end sized .755/.753 for welding onto 3/4 OD tubing

UA201	55.64
--------------------	--------------



**.750-20 SPLINE x
.750-20 SPLINE**

Connects Woodward parts to any other Woodward parts (telescoping column, either end of the servo, splined shaft sections, and all Woodward rack types).

UA20201	57.78
----------------------	--------------



**.750-48 SPLINE x
3/4 WELD-ON**

Fine-pitch serration used on various makes of R&P steering; 3/4-48 was also used on pre-1992 Woodward racks.

UA101	55.64
--------------------	--------------



**.750-48 SPLINE x
.750-20 SPLINE**

Adapts Woodward shaft to the fine-pitch serration used on various makes of R&P steering; 3/4-48 was also used on pre-1992 Woodward racks.

UA20101	57.78
----------------------	--------------



**.735-36 SPLINE x
3/4 WELD-ON**

Fits Mustang power rack, old manual Chevy box, and most steering quickeners.

UA102	55.64
--------------------	--------------



**.735-36 SPLINE x
.750-20 SPLINE**

Adapts Woodward shaft to Mustang power rack, old manual Chevy box, and most steering quickeners.

UA20102	57.78
----------------------	--------------



.720-30 SPLINE x
3/4 WELD-ON

Fits current-model GM power steering including the 600 series box and all servos using 600 series parts (Appleton, small style Sweet, etc.).

UA103 55.64



.720-30 SPLINE x
.750-20 SPLINE

Adapts Woodward shaft to current-model GM power steering including the 600 series box and all servos using 600 series parts (Appleton, small style Sweet, etc.).

UA20103 57.78



.820-36 SPLINE x
3/4 WELD-ON

Fits older-model GM power steering (700 series box) and large style Sweet servo.

UA104 55.64



.820-36 SPLINE x
.750-20 SPLINE

Adapts Woodward shaft to older-model GM power steering (700 series box) and large style Sweet servo.

UA20104 57.78



.620-36 SPLINE x
3/4 WELD-ON

Fits OEM Vega steering box; may not fit aftermarket copies

UA105 55.64



.620-36 SPLINE x
.750-20 SPLINE

Adapts Woodward shaft to OEM Vega steering box; may not fit aftermarket copies

UA20105 57.78



.565-26 SPLINE x
3/4 WELD-ON

Fits Pinto manual rack and most aftermarket copies.

UA106 55.64



.565-26 SPLINE x
.750-20 SPLINE

Adapts Woodward shaft to Pinto manual rack and most aftermarket copies.

UA20106 57.78



.625-36 SPLINE x
3/4 WELD-ON

Fits Stilletto rack and pinion.

UA107 55.64



.625-36 SPLINE x
.750-20 SPLINE

Adapts Woodward shaft or slide yoke to Stilletto rack and pinion.

UA20107 57.78



.688-34/36 SPLINE x
3/4 WELD-ON

Fits Delphi 600 series box used on Toyota truck. Has one filled or "block" spline; not indexable on the steering box.

UA108 55.64



.688-34/36 SPLINE x
.750-20 SPLINE

Adapts Woodward shaft to the Toyota 600 box. Has one filled or "block" spline; not indexable on the steering box.

UA20108 57.78



3/4-DD x
3/4 WELD-ON

Fits Ford type DD and aftermarket DD shaft measuring .550 across the flats.

UA109 55.64



3/4-DD x
.750-20 SPLINE

Adapts Woodward shaft to Ford type DD and aftermarket DD shaft measuring .550 across the flats.

UA20109 57.78



.563-36 SPLINE x
3/4 WELD-ON

Fits Jack Knight, Titan, etc., Formula One and Indy racks.

UA110..... 55.64



.563-36 SPLINE x
.750-20 SPLINE

Adapts Woodward shaft to Jack Knight, Titan, etc., Formula One and Indy racks.

UA20110..... 57.78



.625-23/36 SPLINE x
3/4 WELD-ON

Fits TRW power rack and pinion used in Australia and other right hand drive markets.
Uses 23 spaces out of 36; not indexable on the rack.

UA111..... 55.64



.625-23/36 SPLINE x
.750-20 SPLINE

Adapts Woodward shaft to Australian TRW power rack. *Uses 23 spaces out of 36; not indexable on the rack.*

UA20111..... 57.78



.585-29 SPLINE x
3/4 WELD-ON

Fits Honda and aftermarket racks using Honda spline.

UA112..... 55.64



.585-29 SPLINE x
.750-20 SPLINE

Adapts Woodward shaft to Honda and aftermarket racks using Honda spline.

UA20112..... 57.78



.570-28 SPLINE x
3/4 WELD-ON

Fits Datsun 240/260/280Z

UA113..... 55.64

.570-28 SPLINE x
9/16 (OEM shaft) WELD-ON

UA113Z 55.64



.570-28 SPLINE x
.750-20 SPLINE

Adapts Woodward shaft to Datsun 240/260/280Z

UA20113..... 57.78



3/4 WELD-ON x
3/4 WELD-ON

Plain weld-on style steering joint; the actual bore diameter is .755/.753 so as to admit 3/4" OD tubing, which is typically oversize.

UA100 53.50



5/8 WELD-ON x
5/8 WELD-ON

UA150 53.50

5/8 WELD-ON x
3/4 WELD-ON

UA151 53.50

Welding U-joints and Stubs to Steering Shafts

While it has become obvious over many years that universal joints can be welded to shafts with a high degree of reliability, some procedures are detrimental to the u-joint and must be avoided. **Plug or rosette welds on universal joints are virtually guaranteed to shorten the life of the bearings from both direct heat and the distortion resulting from weld contraction in proximity to the bearing bores.** Even if the bearings are removed first, this distortion will cause enough ovality and misalignment to damage both the bearings and the trunnion journals when reinstalling. In any case, the cross section of a circumferential weld joint is comfortably larger than that of a tubular steering shaft, and any additional welding in the form of plugs or rosettes would be entirely superfluous.

In general, **any welding procedure which consumes enough time to discolor the ears of the u-joint should be assumed to have drawn the temper of the bearings.** This does not necessarily disqualify the TIG process, but TIG does tend to be fairly slow. To avoid heat-soaking the joint when TIG welding, use a high-strength, non-cracking filler rod such as 309 stainless and keep the cross-section small. The most practical method is MIG, as a comfortably large weld can be made in a few seconds. ER80S-D2 wire using C-25 shielding gas will give excellent results for both strength and appearance.

The obvious disadvantage of any welding is, of course, that once you've welded the u-joints they cannot be removed without resorting to a torch, saw, or angle grinder. A mechanical connection, on the other hand, carries the great convenience of being removable for inspection or replacement. Welding splined stubs into the steering tube is no more work than welding u-joints directly to it. However, by confining the welding to the tube, potential heat damage to the u-joint bearings is eliminated. A full-penetration circumferential weld of the stub to the tube will transmit steering torque as effectively as the tube itself, and is not difficult.

With a weld-in stub, plug or rosette welds can be added if desired. If so, use two; these should be as directly opposite each other as possible to equalize the inevitable distortion. The pilot of the splined stub is made a few thousandths oversize to ensure a tight fit in the expected ID of a .120 wall tube. File the pilot if necessary until it fits the tube snugly. A heavy driven fit is unnecessary and will restrain the weld joint. **Leave a 1/8" gap at the root of the weld** to ensure penetration. For the circumferential weld, a couple of hot MIG passes (use a rolling fixture if you can) will get the job done before any significant distortion can set in.

Although a steering shaft is not a high-speed rotating assembly, straightness is still a practical goal. If you prefer TIG welding, excellent results will be obtained using 309 stainless steel filler rod as above. However, keep in mind that TIG is relatively slow; the slower the welding process, the more your finished job is likely to deviate from straight. Postheat to a faint red and let cool in air (Note: don't postheat a universal joint).

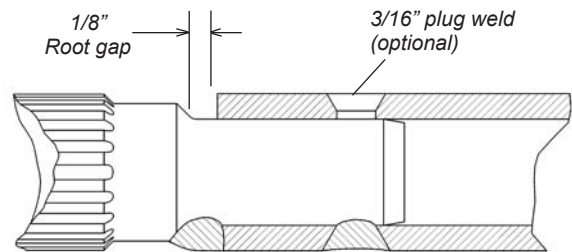

Phasing and Clocking of Universal Joints

Phasing or "clocking" of the universal joints for smooth operation is discussed at some length in Rack and Pinion Tech and is especially important when welding u-joints directly to the shaft, since it will be impossible to reposition them once you've done it. **As a general rule, any back-to-back pair should be aligned like the ends of a driveshaft, as in the illustration at right.** Please study it closely; the difference is not obvious unless you are looking for it. The greater the angular misalignment of the steering shaft, the more critical the phasing of the u-joints. For reference, most stock car steering layouts will tolerate joints 20 degrees out of phase, but 45 degrees out will cause a noticeable change in rotational velocity—the steering will actually speed up and slow down within half a turn of the steering wheel. Shafts with both angular and parallel misalignment may require special u-joint phasing which can only be found by trial and error. In

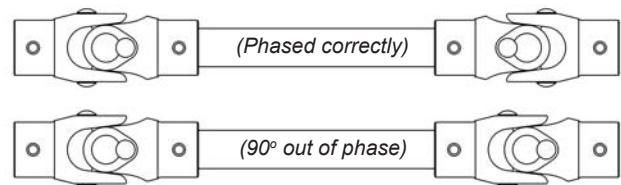

the case of weld-on u-joints, this can be done by temporarily holding one of the joints onto the shaft or tube with a set screw (or even a small tack weld) welding it permanently in place only after you have determined its optimal position.

Timing the Steering Wheel Position to the Rack Travel

When a universal joint operates at a zero angle, it rotates at a constant velocity like a solid shaft. As it is called upon to transmit rotation "around a corner," that is, through an operating angle, its velocity accelerates during a given quarter-turn and then decelerates during the subsequent quarter-turn. The greater the operating angle, the more this action speeds and slows the car's steering. This can be tested by measuring the travel of the rack at 45-degree intervals. For example, turn the steering wheel through some arbitrary angle (like 20 degrees; it doesn't matter how far, provided you turn it the same each time) and measure the rack travel. Reposition the wheel at 45 degrees, turn it 20 degrees and again measure the rack travel. Checking every 45 degrees will reveal a pattern. Note that a rack which travels 2.09 inches in 360 degrees should theoretically travel .116 inch in 20 degrees. If your u-joints operate through considerable angular misalignment you may discover your rack travels .180 inch when turned from the initial or twelve o'clock steering wheel position, but slows down to .050 inch from the nine o'clock position and speeds up again to .180 inch from the six o'clock position. This sort of thing can make high-speed cornering highly unpredictable. The classic example is a sudden spinout resulting from a small steering wheel input. The output at the rack at that point may be disproportionately large. Of course this is frustrating to the driver but virtually impossible to pin down without doing the above test. It's easier to blame the tires.

There are two ways to address the problem. As a quick partial fix, disconnect the steering shaft from the pinion and reconnect it so the speedup and slowdown is timed to occur symmetrically about center—or on an oval track car, symmetrically about the most-used position of the steering wheel. Second, replace the most severely-angled u-joint (usually the one at the firewall) with a double joint. The double joint will smooth out the rotation to practically constant velocity.

Double Universal Joints

Double U-joints neatly solve problems of angular misalignment by providing smoother rotation than a single joint used at the same operating angle. The 20-tooth spline in a Woodward U-joint is timed with respect to the bearing axis, so any two joints assembled back-to-back on a 20-spline shaft will have parallel axes and will be in phase for maximum efficiency. Although the angular misalignment capacity of a double U-joint is theoretically twice that of a single joint, it is always best to keep angular misalignment of the steering to a minimum.

Double universal joints develop greater side reaction than single joints and require support at both ends to prevent deflection. Any end not connected to a rigidly mounted component (such as a steering gearbox or rack and pinion) must have a rod end or other bearing placed as close to the U-joint as practical. While it is sometimes possible to get away with placing the bearing as much as 4 inches distant from an ordinary U-joint, this is highly inadvisable with a double joint.

Important: A double joint with a single rod end or other bearing in the middle is UNSTABLE unless the double joint is directly connected to a fixed component. Wherever possible, support a double u-joint at the ends.



SHAFTS for the above double u-joints will accept any 201 splined half. The set-screw grooves are located .5 inch in from each end.

1.75 overall UADS-3.....	8.00
2.75 overall UADS-4.....	8.75
3.75 overall UADS-5.....	9.50

CUSTOM SHAFTS:
Specify overall length (will have set-screw grooves unless otherwise specified).
UADS-X..... 12.00

PERMANENT-TYPE DOUBLE UNIVERSAL JOINTS are pre-aligned to ensure correct phasing.

2.18" bearing centers

.750-20 x .750-20 UAD1-20201	122.25
.750-20 x .750-48 UAD1-20101	122.25
.750-20 x .735-36 UAD1-20102	122.25
.750-20 x .720-30 UAD1-20103	122.25
.750-20 x .565-26 UAD1-20106	122.25
.750-20 x .625-36 UAD1-20107	122.25
.750-20 x 3/4-DD UAD1-20109	122.25

Other spline combinations are available on special order at no additional cost. Any Woodward u-joint can be incorporated into a permanent-type double u-joint.

SHAFT-MOUNTED DOUBLE U-JOINT ASSEMBLIES are prealigned for correct phasing. Both ends are removable.

3-5/8" bearing centers

.750-20 x .750-20 UAD3-20201	122.26
.750-20 x .750-48 UAD3-20101	122.26
.750-20 x .735-36 UAD3-20102	122.26
.750-20 x .720-30 UAD3-20103	122.26
.750-20 x .565-26 UAD3-20106	122.26
.750-20 x .625-36 UAD3-20107	122.26
.750-20 x 3/4-DD UAD3-20109	122.26

4-5/8" bearing centers

.750-20 x .750-20 UAD4-20201	124.66
.750-20 x .750-48 UAD4-20101	124.66
.750-20 x .735-36 UAD4-20102	124.66
.750-20 x .720-30 UAD4-20103	124.66
.750-20 x .565-26 UAD4-20106	124.66
.750-20 x .625-36 UAD4-20107	124.66
.750-20 x 3/4-DD UAD4-20109	124.66

5-5/8" bearing centers

.750-20 x .750-20 UAD5-20201	127.06
.750-20 x .750-48 UAD5-20101	127.06
.750-20 x .735-36 UAD5-20102	127.06
.750-20 x .720-30 UAD5-20103	127.06
.750-20 x .565-26 UAD5-20106	127.06
.750-20 x .625-36 UAD5-20107	127.06
.750-20 x 3/4-DD UAD5-20109	127.06

Other spline combinations are available on special order at no additional cost. Any Woodward u-joint with the 201 spline at one end can be incorporated into a shaft-mounted double u-joint.

Weld-on splined couplers

Highly convenient for welding onto the steering shaft, these can replace universal joints in cases where a floating connection is not required. The coupler is counterbored 1 inch deep to accept 3/4 OD tubing, and the small C110B is available counterbored for 5/8 tubing.

Couplers are useful for splicing a servo into a steering shaft, and also for connecting to a rack mounted in pillow blocks close to the driver (such as the Type MR or MC) provided it is possible to accurately align the steering shaft with the pinion spline. However, a coupler should never be used to connect to a rack where there is any likelihood of misalignment resulting from chassis flex. In such cases (which is to say most race cars larger than formula cars) the rack should always be connected with a universal joint. We can make couplers with any spline provided the counterbore for welding is equal to or larger than the major diameter of the spline.



.750-20
 Fits all Woodward parts (Pinion, servo input and output, safety steering columns, etc.)
C201.....19.75



.750-48
 Fine-pitch serration fits various makes of R&P steering; also found on Woodward racks built before 1992.
C101.....19.75



.735-36
 Fits Mustang power rack and most steering quickeners.
C102.....19.75



.720-30
 Fits current GM power steering boxes and servos using current GM parts such as Appleton and small style Sweet.
C103.....19.75



.820-36
 Fits 4-bolt early GM power steering box and all servos using early GM parts such as large style Sweet. *Note: spline ID is larger than tubing; has extra set screws to align for welding.*
C104.....19.75



.563-26
 Fits Pinto racks and aftermarket copies.
C106.....19.75



.625-36
 Fits Stilletto rack and pinion.
C107.....19.75



.688-34/36
 Has one spline tooth removed to fit Delphi-manufactured Toyota truck box. Not indexable on the steering box but works on other 17.5 mm shafts with base 36 spline.
C108..... 19.75



3/4 DD
 Fits aftermarket DD shafting based on Ford dimensions of .75 diameter x .550 across the flats.
NOT for GM DD shafts.
C109..... 19.75



.563-36
 Fits Jack Knight and Titan racks.
For welding to 3/4 tube:
C110A..... 19.75
For welding to 5/8 tube:
C110B..... 19.75



.625-23/36
 Fits Australian TRW power rack. Uses 23 spaces out of 36. Not indexable on the rack but works on other 16 mm shafts with base 36 spline.
C111 19.75



.585-29
 Fits Honda and aftermarket racks using Honda spline.
C112 19.75



.570-28
 Fits Datsun 240/260/280Z.
C113 19.75



.750-20 SPLINED THROUGH
 Will couple any Woodward part to any other Woodward part without welding. Also useful in industrial applications. *NOTE: for HE racks, use part number VH201 at right.*
CD201 25.00



INTERNAL COUPLER for HE racks
 Installs on the servo output spline and “plugs” the servo into the pinion. This coupler is smaller diameter to fit inside the servo adapter. *NOTE: set screw spacing is special and will ONLY join servo and pinion in an HE rack.*
VHE201 26.50